

VELOCITY DISTRIBUTIONS CURVES FOR HIGH POLLUTED STREAM INSIDE A CIRCULAR PIPE

Moharram Fouad, Kamal Radwan* , and Mohamed Zidan*

** Associate professor of sanitary Engineering, Faculty of Engineering, University of Mansoura,
E-mail: mf12317@gmail.com: m123f12317@yahoo.com*

*** scholar of sanitary Engineering, Faculty of Engineering, University of Mansoura*

ABSTRACT

Velocity distribution curves and values in three coordinates have been obtained for high polluted stream inside a circular pipe experimentally mimicking municipal wastewater moving through sewer system. Consequently, the behavior of such polluted stream was monitored, evaluated, and understood accurately. Consequently, some polynomial formulas were obtained. Water stream was polluted experimentally with sediments as a suspended solids and scum as floating materials. The water stream was run under different conditions of sediments, water depths, and initial velocity. The velocity profiles measurements in three dimensions were obtained using Acoustic Doppler Velocimeter (ADV). The Velocity distributions curves revealed that the velocity distributions in the three coordinates linearly decreased with the increase of sediments and the decrease of temperature. These obtained curves are simple and can be adopted and utilized for any specific stream inside a circular pipe.

Keywords: Velocity distributions curves, ADV, Suspended load, Circular channel.

1 INTRODUCTION

So far, transport of cohesive soils in stream is very interested for much researchers and designers. Despite the complexity of this process, the movement of cohesive soils in stream is very useful to design many streams such as small channels, sewers, and several conduit pipes. Generally, the cohesive soil is distributed with increased concentration from the top to the bottom layers of the stream according to the horizontal velocity value of the stream. At high velocity (2 m /sec), the distribution of the cohesive soils in stream may be uniform, but with a low speed less than 0.6 m / s most of this soil moves coherent in the lower to middle layers of the stream. Conversely, the velocity distribution curves are not only changed but also most of formulae which describe the stream may be changed. Therefore, special experimental studies are still needed in a circular section, to explain the physical and mathematical behavior of that stream having a cohesive soil. These studies are very useful for understanding the concept the sediment transport inside a circular section.

Previously, several researchers such as Arora et al. (1986) investigated the effect of sediment transport on the velocity distribution for rigid boundary channels. Wren et al. (2000) studied the effect of turbulence on the suspended sediment in open channels. Also, Huand Guo (2010) conducted much work on this topic. Despite, many researchers carried out the velocity distributions of streams and a lot of empirical and semi-empirical equations were deduced but all of these equations have been adopted based on a rectangular section (Nezu and Rodi; 1986; Nezu and Nakagawa 1993; Mazumder and Ghoshal, 2006) however velocity equations of stream inside a circular section are very limited. Velocity in uniform sediment laden flow was presented by Umeyama and Gerristen (1992).

Suryanarayana and Shen (1971) and Pellachini(2011)carried out extensive laboratory flume studies for three different particle size sediments using cohesive soil.Grant et al. (2013) studied mechanics of sediment through culverts in addition toMilad et al. (2015)who presented convenienttransport formula that can be used to explain behavior of the cohesive soil inside some culverts.

Ashely and Verbanck (1996) studied the mechanics of sediment erosion and transport in sewers. Recently, velocity distribution in circular flume was highlighted by Ramalingham and Chandra (2016).

Mucha et al. (2004) did a model to study the velocity fluctuations in the presence of sediment transport.Man (2007) made a stochastic modeling of suspended sediment transport in regular and extreme flows.Silvigani et al. (2014) studied the sediment transport in a combined sewer network.

The effect of temperature on the flow characteristics and sedimentation rate were given by (Rogers et al., 1964; Sarmiento and Urlherr, 1979; Liu et al., 1994; Goula et al., 2008; Winkler et al., 2012).

An experimental study was carried outby doing a lot of runs in manufactured circular laboratory flume in the Irrigation and Hydraulics Dept., Faculty of Engineering, Mansoura University, Mansoura, Egypt. Consequently, the present study highlights the effect of transport of cohesive soil (as sewer suspended solids pollution) on the velocity distributions inthe three dimensions coordinates using Acoustic Doppler Velocimeter (ADV) instrument. Finally,the relationships that describe the movement behavior of the cohesive soil are also realized.

2 MATERIALS AND METHODS

A circular channel with adjustable slope has been designed and constructed by the authors using 200 mm diameter and length of 4.8 m PVC pipe as given in figure (1) and Plate (1). The flume was equipped with point gauge for measurements of water depth(Plate 2) and Acoustic Doppler Velocimeter (ADV)as shown in plate (2,a,b) for measuring the water velocity in the three dimensions. Water depth was measured using a point gauge to an accuracy of 0.1 mm. The experimental work has been carried in the hydraulic laboratory of the department of Irrigation and Hydraulics at Mansoura University.

Water was supplied to the head tank, upstream the flume through 75 mm diameter supply pipe from a ground tank (Figure 1). The head tank is 30 x 38 cm square and 60 cm depth and is provided by screen to damp the turbulence of the flow. Water discharges into a tank 150x70 cm square and 28 cm depth from which the water is continuously pumped to the constant head tank by submersible pump having a power of 0.3 kw input and 0.15 kw output.

The channel was equipped with a submersible pump of constant discharge;however, the desired discharge was controlled using control valves. So, different discharges were used and different water depth was controlled for each discharge via a tail gate located at the channel end(plate 2d). Cohesive soil (clay) was collected, dried, and mixed with the stream using different concentration of 1, 2, 3, 4, and 5 gm/lit. and at the clayconcentration of 5gm / lit. a scum was added using different concentration of 1,2 3, 4, and 6 gm /lit. A total of 350 experimental runs were carried out atdifferentcontrolled temperature ranged from 20 C^o to 9 C^o. The temperature of the wastewater was controlled using ice plates which were added to the sump tank. Different values of relative total depth (d/D) varied between 0.41 and 0.75 were used. The mean velocity was estimated by dividing the discharge by the water cross section area as well confirmed using

Acoustic Doppler Velocimeter (ADV). Further, the velocity components were continuously monitored in the three dimensions using ADV monitor at any depth (y), Plate (2 e).

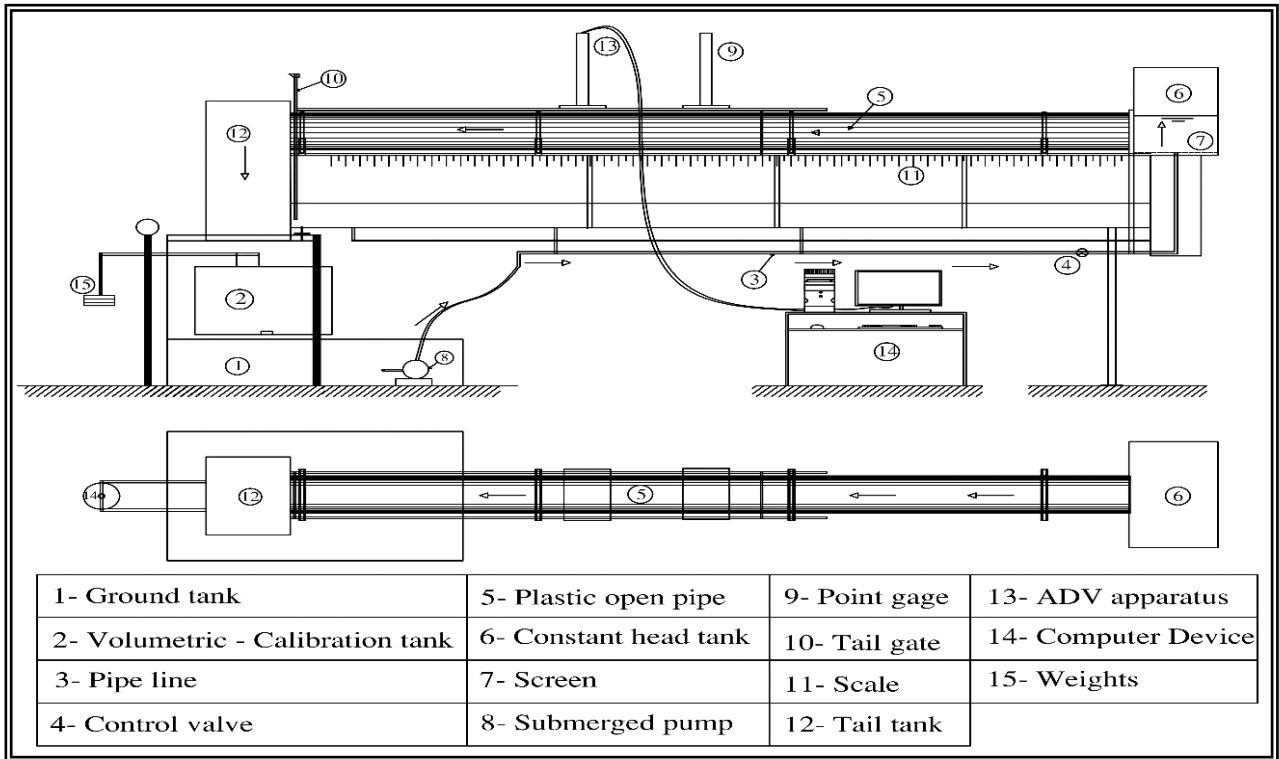

Figure 1. Sketch showing the flume used in the study

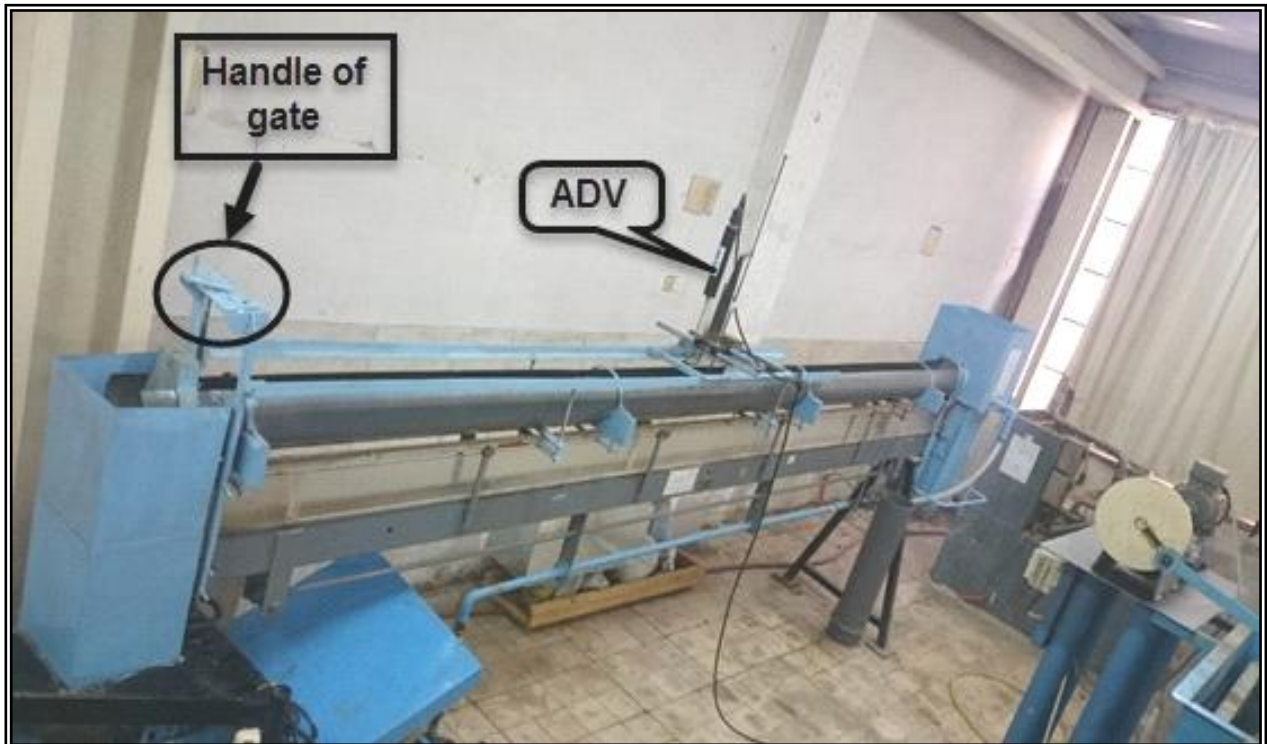

Plate (1): Flume used in the study

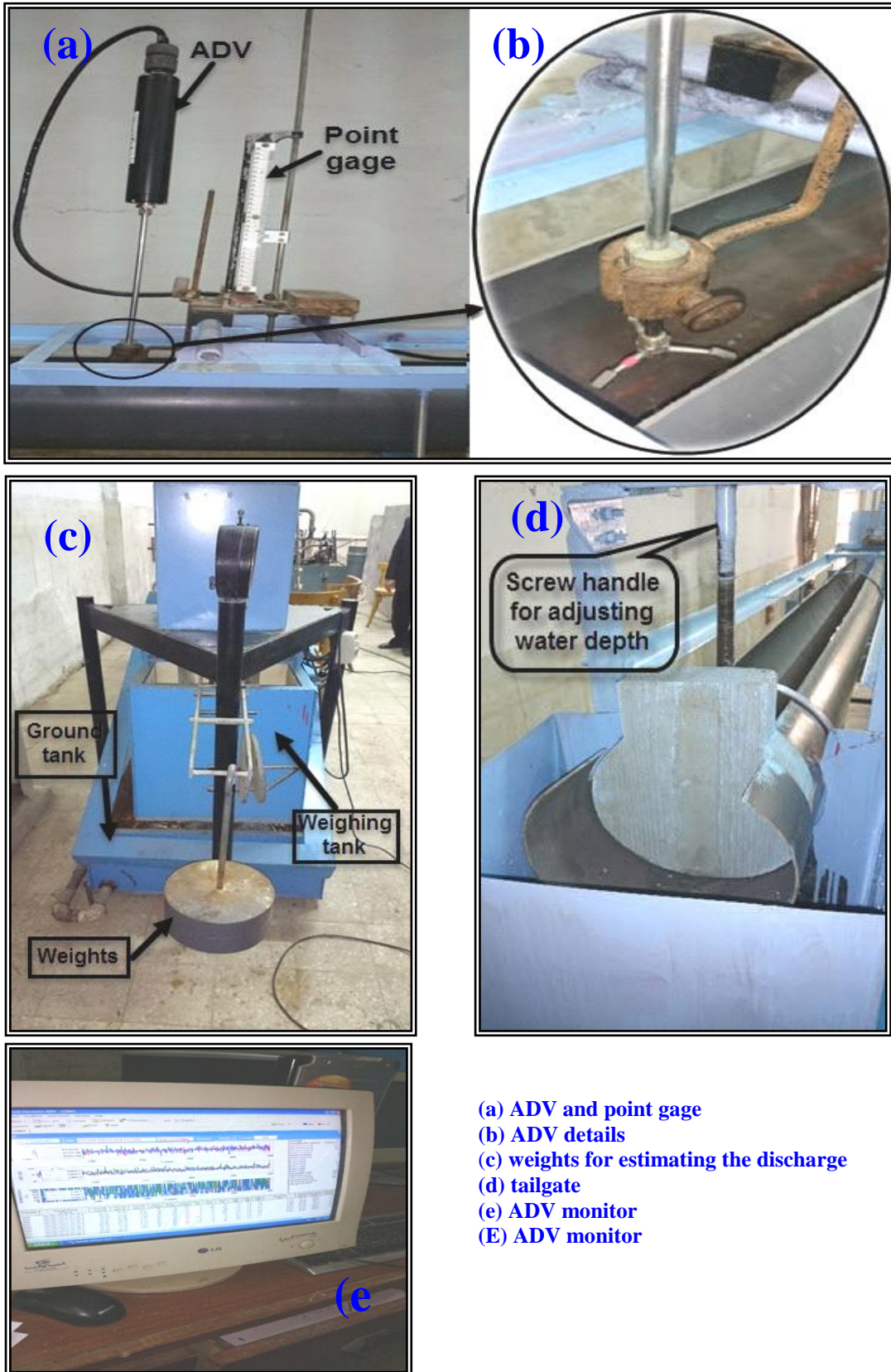

Plate (2): Details of the flume components

3 DIMENSIONAL ANALYSIS

A dimensional analysis was carried out using Buckingham theorem for the given physical phenomenon, using a sort of compacting technique. The dimensional analysis was based on a method for computing sets of dimensionless parameters from given variables even if the form of equation is still unknown which are the characteristics of fluid, flow, and boundary.

Fluid Characteristics

ρ : water density; C: clay and scum concentrations ;
 σ : surface tension; μ : viscosity; and T : water temperature.

Flow Characteristics

d : water depth; y: water depth from the bottom ; v_m : mean water velocity; V_x : velocity component in the x axis direction; V_y : velocity component in the y axis direction; V_z : velocity component in the z axis direction; Q : water discharge; and g: gravitational acceleration

Boundary Characteristics

S_o : flume bed slope; D : pipe internal diameter.

These parameters could be put in the following form:

$$f(\rho, \sigma, C, \mu, T, d, y, V_m, V_x, V_y, V_z, Q, g, S_o, D) = 0 \quad (1)$$

taking ρ, d, V_m as the repeating variables and neglecting numbers of Reynolds Froude r and Weber.

This study will concentrate on the stream line velocity i.e. V_x , and flume bottom slope is kept constant.

Then, equation (1) can be rewritten as:

$$f'(d/D, y/d, V_x/V_m, C/Q, T) = 0 \quad \dots \dots (2)$$

in which: d/D relative total depth; y/d relative depth; and V_x/V_m relative velocity. In the above equation units of concentration should have the same units as Q.

Mean velocity calculation

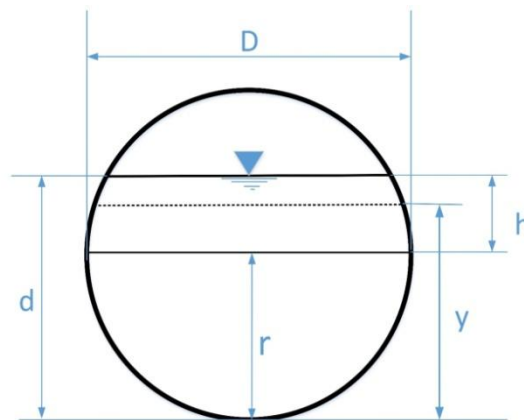

Figure 2.Sewage pipe cross section

Where:

D: pipe diameter (cm); d: water depth (cm); d/D : relative total water depth; A: water area (cm²); y: depth from bottom to point of measurement (cm); and h= d-r

$$A: \text{water area} = \frac{1}{2}r^2(\pi + 2 \sin^{-1}(\frac{h}{r}))$$

V_m : mean velocity = Q/A

in which Q is the sewage water discharge (cm³/sec)

It was found from the experimental work that there is a maximum value of concentration at which the suspended sediment begins to settle as a bed load. This value is known as a critical value of concentration and the corresponding velocity is known as the critical velocity. Figure (2) presents velocity distribution of water with suspended sediments for circular pipe .

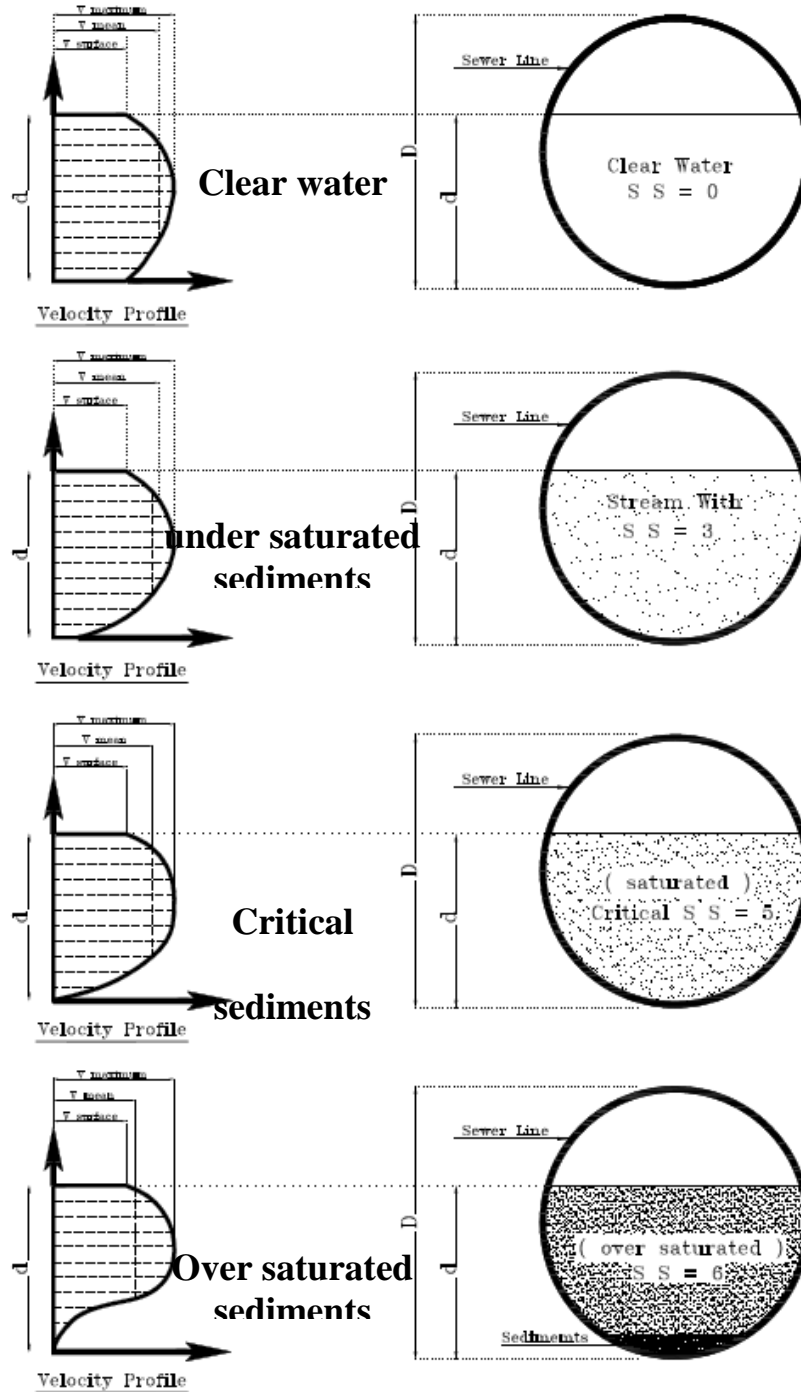

Figure 3. Velocity distribution of water with suspended sediments

4 RESULTS AND DISCUSSIONS

4.1 Effect of Clay Concentration on Velocity Distribution

Increase of clay concentration could decrease the value of the streamline velocity V_x as shown in table (1). The two other values of velocities V_y and V_z could decrease or increase, that is mainly due to diffusion process of clay.

It should be mentioned that the any noise in the hydraulic laboratory will influence the ultrasonic dependence ADV apparatus and consequently the recorded velocities values.

Considering the water depth to be constant, increasing the clay concentration from 2 gm/lit, 3 gm /lit and 4gm /lit will decrease the value of V_x velocity at 0.7 d by 2.33 %, 10.61 % respectively. The same increase of concentration gives V_x decrease by 2.19 %, 6.42 % at 0.8d and by 2.63 %, 3.01 % at 0.9 d respectively.

Table (1) Effect of clay concentration on the velocity components T =18° C

Y cm	2 gm / lit d=8.8			3 gm / lit d=8.6			4 gm /lit d = 9 cm		
	V_x	V_y	V_z	V_x	V_y	V_z	V_x	V_y	V_z
.7 d	11.024	0.723	-0.440	10.767	1.297	-0.381	9.864	0.088	-0.569
.8 d	11.731	-0.378	-0.652	11.474	1.558	-0.661	10.978	-0.69	-0.786
.9 d	11.850	-0.199	-0.988	11.538	0.471	-0.734	11.493	0.267	-0.96

4.2 Effect of Discharge on Velocity Distribution

Table (2) highlights values of the velocity components for the two values of discharge (1.4 lit/ sec. and 1.03 lit/ sec.) for 5gm/ lit clay concentration, water depth d = 10 cm, and temperature T =18° C. It is noticed that V_x decreases with decreasing discharge, while increasing values of the transverse component V_y and the vertical component V_z .

Decreasing of water discharge will decrease the values of velocity at the same depth for all values of clay and scum concentrations. For example, decreasing the value of discharge from 1.4 lit /sec to 1.03 lit/ sec. decreases the value of discharge by 34 %, 28.87 %, and 26.55 % at 0,6 d, 07 d and 0.8 d respectively.

Table (2) Effect of discharge value on velocity components

y cm	1.4 lit/ sec			1.03 lit/sec		
	V_x	V_y	V_z	V_x	V_y	V_z
0.6d = 6 cm	7.944	-0.191	-0.270	5.244	-1.016	-0.283
0.7d = 7 cm	8.707	0.126	-0.422	6.193	1.862	-0.429
0.8d = 8 cm	9.662	0.650	-0.669	7.097	1.092	-0.506

4.3 Effect of Water Temperature on Velocity Distribution

Reducing water temperature decreases the value of stream velocity V_x by 16.62 % at 0.5 d, 8.4% at 0.6 d and 6.89 at 0.7 d in case of a 13 cm water, Table (3). It is also noticed corresponding

decrease of the velocity component in the vertical direction V_z and an increase of the transverse component in the direction V_y .

Table (3): Influence of water temperature on the water velocity (clay concentration = 5 gm/lit, scum concentration=6gm/lit at d= 13.3 cm and Q= 1.5 lit/sec).

Y cm	T=18° C			T=9° C			percentage of reduction
	V_x	V_y	V_z	V_x	V_y	V_z	
0.5d=6.35	6.889	0.239	-0.04	5.744	0.682	-0.226	16.62
0.6d=7.62	6.862	0.886	0.098	6.287	0.996	-0.279	8.40
0.7d=8.89	7.188	0.593	-0.041	6.686	1.409	-0.377	6.98

4.4 Effect of Scum Concentration on Velocity Distribution

For the same discharge, water depth, and temperature, (1.5 lit/ sec, 9.5 cm, and 18 C° respectively increasing cum by 2gm/ lit decreases the V_x by 43.1 % at 0.7 d, 31.4 % at 0.8 d and by 5.4 % near the water surface (0.9 d), Table (4), which means this value decreases towards the water surface. It is also noticed corresponding decrease V_y .

Table (4): Influence of scum concentration on the water velocity distribution at 18° C at water depth d= 9.5cm (clay concentration = 5 gm/lit and Q= 1.5 lit/sec).

Y cm	4 gm / lit scum			6 gm / lit scum			percentage of reduction
	V_x	V_y	V_z	V_x	V_y	V_z	
0.7d=6.65	12.877	0.350	-0.998	8.360	0.78	-0.254	43.1
0.8d=7.6	14.698	0.488	-0.797	9.162	0.70	-0.315	31.4
0.9d=8.55	13.356	0.156	-0.669	7.357	-1.233	-0.037	5.4

4.5 Effect of water temperature and Scum Concentration

Decrease of temperature of the wastewater and increasing the value of scum concentration decreases the value of velocity. For example, at Q equal 1.5 lit/ sec and a depth of 11 cm increasing the value of scum concentration from 4 gm/ lit to 6 gm /lit and reducing the water temperature from 18 C° to 9 C°, there will be V_x reduction by about 27.15 % at 0.6d, 24.33 % at 0.7 d, 22.71 at 0.8 d and 10 % near water surface (0.9 d), Table (5). This means the reduction percentage decreases towards water surface. It is also noticed the increase of the velocity components in both vertical and transverse directions V_z and V_y .

Table (5): Influence of water temperature and scum concentration on velocity distribution at water depth 11cm (clay concentration = 5 gm/lit and Q= 1.5 lit/sec).

Y cm	4 gm /lit scum and T=18° C			6 gm / lit scum and T=9°C			percentage of reduction
	V _x	V _y	V _z	V _x	V _y	V _z	
0.6d=6.6	10.220	-1.762	-0.651	7.445	0.339	-0.301	27.15
0.7d=7.6	11.313	0.175	-0.667	8.560	0.211	-0.377	24.33
0.8d=8.7	11.738	-0.114	-0.592	9.072	0.036	-0.328	22.71
0.9d=9.9	10.000	1.475	-0.734	9.004	0.596	-0.347	10.00

4.6 Derived Equations.

1. Q= 1.5 lit/sec, concentration of 5 gm/lit clay plus 6 gm/lit at 9°C

Linear, exponential, logarithmic, and polynomial from the second degree relationships between water depth y and velocity V_x, were testified and also between the relative depth y/d and the relative velocity V_x/ V_{mean} for different values of relative total depth (d/D)

Of all tested relationships, it was found that the highest value of determination coefficient (R²) is given by the polynomial from the second degree:

• **For depth 13.3 cm**

$$\frac{v}{v_m} = -3.65 \left(\frac{y}{d}\right)^2 + 5.62 \left(\frac{y}{d}\right) - 1.33 \quad R^2 = 0.890$$

• **For depth 10.8 cm**

$$\frac{v}{v_m} = -2.22 \left(\frac{y}{d}\right)^2 + 4.04 \left(\frac{y}{d}\right) - 8.03 \quad R^2 = 1$$

Relationship between y and V

• **For depth 13.3 cm**

$$V = -0.162 y^2 + 3.32 y - 10.48 \quad R^2 = 0.89$$

• **For depth 10.8 cm**

$$V = -0.173 y^2 + 3.40 y - 7.52 \quad R^2 = 1$$

2. Q = 0.88 lit/sec, concentration of 5 gm/lit clay plus 6 gm/lit at 9°C

3.

• **For depth 14.3 cm**

$$\frac{v}{v_m} = 8.71 \left(\frac{y}{d}\right)^2 - 9.31 \left(\frac{y}{d}\right) + 3.02 \quad R^2 = 1$$

• **For depth 13.6 cm**

$$\frac{v}{v_m} = 0.214 \left(\frac{y}{d}\right)^2 - 0.23 \left(\frac{y}{d}\right) + 0.40 \quad R^2 = 0.80$$

• **For depth 11 cm**

$$\frac{v}{v_m} = -1.18 \left(\frac{y}{d}\right)^2 + 1.84 \left(\frac{y}{d}\right) - 0.29 \quad R^2 = 0.99$$

Relationship between y and V

• **For depth 14.3 cm**

$$V = 0.214 y^2 - 3.11 y + 13.70 \quad R^2 = 1$$

• **For depth 13.6 cm**

$$V = 0.009 y^2 - 0.11 y + 2.11 \quad R^2 = 0.80$$

• For depth 11 cm

$$V = -0.035 y^2 + 0.73 y - 1.97 \quad R^2 = 0.97$$

y : water depth at measuring surface; ; $V = V_x$ streamlined velocity; V_m : mean velocity; d : total water depth; D: pipe diameter.

y/d : relative water depth; d/D : relative total depth.

Figure (3) presents the dimensionless relationship between relative water depth (y/d) and relative velocity (V/V_{mean}) for relative total depth with two values of discharge.

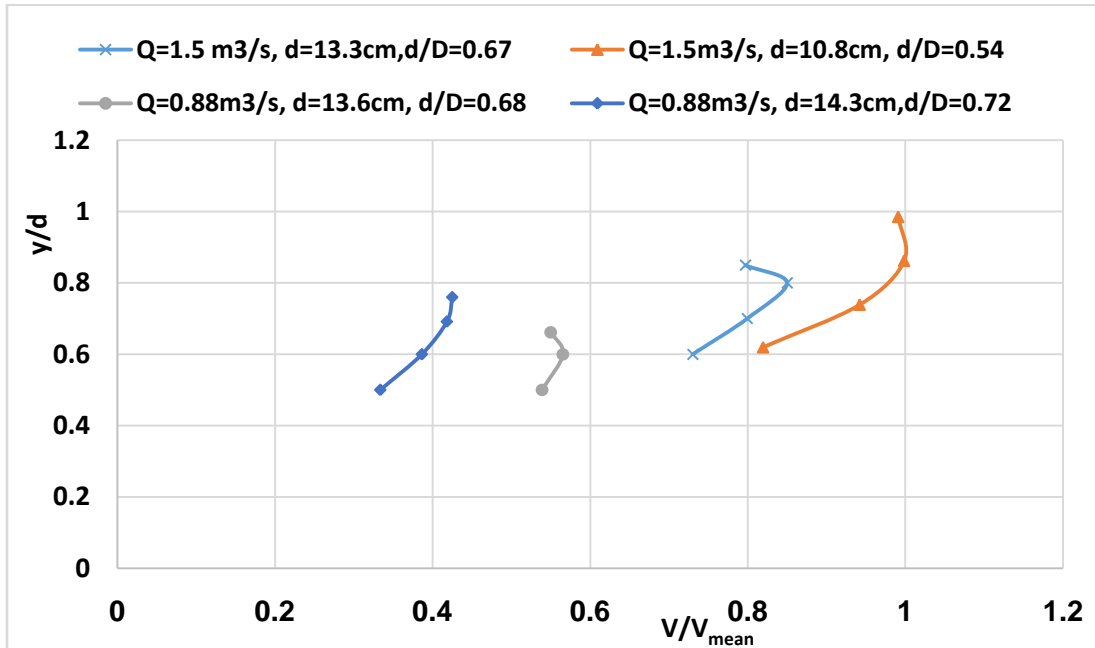

Figure (3) Dimensionless relationship between relative water depth (y/d) and relative velocity (V/V_{mean})

5 CONCLUSIONS

From the above work the following conclusions can be drawn:

*Transport of cohesive soil reduces the velocity distribution in the three directions, but the stream (horizontal) direction is the most affected direction by the cohesive soil and reduced by about 20% from its initial value (free-clay case).

*For each circular section there exist critical mean velocity that can transport a critical concentration of cohesive soil mixed with the stream. At the critical conditions of the soil concentration and mean velocity, the velocity of the bottom layer is zero. At this critical condition all the soil particles are moving with the stream despite the maximum concentration of soil that found near the bottom with no sediments. In additions, at these critical conditions, the velocity of the bottom layer that attached to the channel is vanished. The relation between the maximum concentration of soil and the mean stream velocity starts linear then turns into polynomial.

* The temperature effect was significant for the velocity variations, so decreasing the temperature from 18C° to 9 C° may decrease the velocity by about 17 % causing negative impacts on sewer networks efficiency during cold winters.

*The velocity variation is very sensitive to the scum concentration, as increasing the scum concentration from 4 gm lit/ to 6g /lit may decrease the stream velocity by about 43 %.

* The velocity reduction against the sediment content is not linear rather than polynomial order.

* Dimensionless polynomial equations from the second degree have been derived which could be used to describe the velocity reduction against the sediment content and operation parameters which is simple and easy as well as can be modified for any specific condition and sediment content.

ACKNOWLEDGEMENT

This paper is a part of M.Sc. thesis of the third author (under preparation) , Sanitary Engineering Dept., Mansoura University, Egypt, under the supervision of the other two authors.

REFERENCES

Arora, A, Raju, k and Garde, R (1986). Resistance to flow and velocity distribution in rigid boundary channels carrying sediment laden flow, Journal of Water Resources Research, Vol. 22, No. 6, pp. 943-951

Ashely, R and Verbanck, M (1996). Mechanics of sewer sediment erosion and transport, Journal of Hydraulic Research, Vol. 34, No. 6.

Goula, A, Kostoglou, M, Karapantsios, T and Zouboulis, A (2008). The effect of influent temperature variations in a sedimentation tank for potable water treatment – A computational fluid dynamic study, Journal of Water Research, Vol. 42, pp. 3405-3414

Grant, j , Waklery T, Hill, P and Linter, D (2013). Beast- a portable device for quantification erosion in intact sediment core, Methods in Oceanography.

Hu, C Ji, Z and Guo, Q (2010). Flow movement and sediment transport in compound channels , Journal of Hydraulic Research ,Vol. 48 , No. 1, pp. 23-32.

Liu, C, Gooi, B, Wong, Y and Yeo, J (1994). The effect of inlet velocity distribution on temperature field of rotating circular pipe, Journal of International Communications in Heat and Mass Transfer, Vol. 21, No. 6, pp..829-837, El-Sevier.

Man, C (2007). Stochastic modeling of suspended sediment transport in regular and extreme flow environments, Report, Faculty of the Graduate School of the State University of New York.

Mazamander, B and Ghoshal, K (2006). Velocity and concentration profiles in uniform sediment laden flow, Applied Mathematical Modeling, Vol. 30, No. 2pp. 163-176.

Milad, K, Kyle,S, and Qin, Q (2015). A literature review on sediment transport process in shallow grade culverts and storm sewers, Proceedings of ASEE, Gulf South Annual Conference, University of Texas.

Mucha, P, Tee, S, Weitz, D, Shraiman, B and Brenner, M (2004). A model for velocity fluctuations in sedimentation, *Journal of fluid mechanics*, Vol. 51, pp. 71-107.

Nezu, I, and Nakagawa, H (1993). *Turbulence in open channel flow*, IAHR Monograph, Balkema Publishers, The Netherland.

Nezu, I, and Rodi, W (1986). Open channel flow measurements with laser Doppler anemometer, *Journal of Hydraulic Engineering*, ASCE, Vol. 112, pp.335- 355.

13.Pellachini, I (2011). *Modeling fine sediment transport over an immobile gravel bed*, Toronto University ,e prints.

Ramalingam, S and Chandra, V (2016). Velocity distribution in circular flume, 8th International Perspective on Water Resources and the Environment American Society of Civil Engineers/Environmental and Water Resources Institute

Rogers, K and Lond, M (1964). Effect of temperature on sedimentation rate, *The Lancet*, Vol. 248, No. 6424, pp.. 520-522

Sarmiento, G and Urlherr, P (1979). The effect of temperature on the sedimentation parameters of flocculated suspensions, *Journal of Power Technology*, Vol. 22, No. 1, pp.. 139-142, ELSEVIER

Silvagni, G, Volpi, F and Celestini, R (2014). Sediment transport in sewer: the Cesarina combined sewer network, *WIT Transactions on Ecology and The Environment*, Vol. 182

Suryanarayana, B, and Shen, W (1971). Laboratory study of degradation and aggradations, *Journal of Water way and Harbors, and coastal Engineering Division*, Vol. 97, pp. 615-630.

Umeyama, M and Gerritsen, F (1992). Velocity distribution in uniform sediment laden flow, *Journal of Hydraulic Engineering*, Vol. 118, No. 2.

Winkler, M, Bassin, J, Kleerebezem, R, Van der lans, R and Van Loosdrecht, M (2012). Temperature and salt effects on settling in velocity in granular sludge technology, *Journal of Water Research*, Vol. 46, pp. 3897-3902

Wren, D, Bennett, S, Barkdoll, B and Kuhnle, R (2000). Studies in suspended sediment and turbulence in open channels flows, *Research Report No. 18, USDA*.